

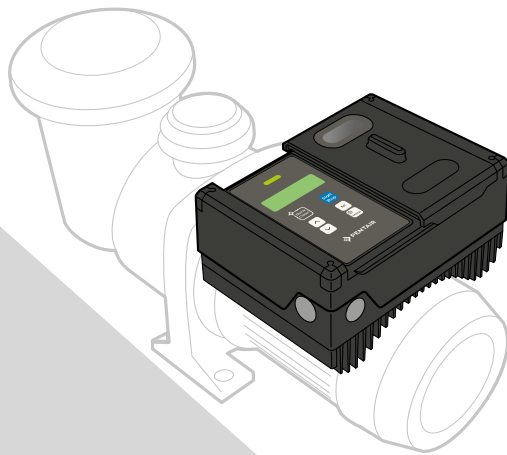

VSe VARIABLE SPEED PUMPS

INSTALLATION AND USER'S GUIDE



IMPORTANT SAFETY INSTRUCTIONS
READ AND FOLLOW ALL INSTRUCTIONS
SAVE THESE INSTRUCTIONS

EN

Pentair thanks you for your trust and for purchasing the Pentair VSe.
To fully enjoy all the features of your VSe, please read this operating manual carefully. Store it carefully so that it can be consulted at any time.



Declaration of conformity

Guidelines – Harmonised standards

Pentair International Sarl - Avenue de Sévelin 20 - 1004 Lausanne - Switzerland

We hereby declare under our sole responsibility that this product complies with the relevant guidelines

LVD	2014/35/EU	EN 60335-1:2012/A11:2014	EN 61000-6-1:2007
EMC	2014/30/EU	EN 60335-2-41:2003/A2:2010	EN 55014-1:2006/A2:2011
	2000/14/EC	EN 60730-1:2011	EN ISO 20361:2009
		EN 61000-6-3:2007/A1:2011	



© 2023 Pentair International LLC, All rights reserved
- Internet site: www.pentairpooleurope.com

- The document is subject to change without notice

Trade names and waivers: Pentair VSe and Pentair are trade names and/or registered trade names of Pentair and/or companies affiliated to Pentair. Unless otherwise stated, the names and brands of third parties used in the present document are not used to indicate any affiliation or endorsement between the owners of these trade names and Pentair. Those names and brands may be the trademarks or the registered trademarks of these parties, or others.

TABLE OF CONTENT

> 1. ELECTRICAL INSTALLATION	p 05
> 2. CONTROL PANEL OVERVIEW	p 06
> 2.1. DISPLAY	p 07
> 2.2. KEYPAD NAVIGATION	p 07
> 3. PUMP INSTALLATION	p 07
> 3.1. LOCATION	p 07
> 3.2. PLUMBING AND FITTINGS	p 08
> 3.3. VALVES	p 08
> 4. OPERATION	p 08
> 4.1. START-UP	p 08
> 4.2. PRIMING THE PUMP	p 08
> 4.3. USING THE DEFAULT SCHEDULE	p 09
> 4.4. OPERATING THE PUMP WHILE RUNNING	p 10
> 4.5. QUICK CLEAN	p 10
> 4.6. PRIMING	p 10
> 5. USER MENU	p 10
> 5.1. SETTING THE CLOCK	p 11
> 5.2. TO PROGRAM A CUSTOM SCHEDULE	p 11
> 5.3. LANGUAGE SELECTION	p 12
> 5.4. EXTERNAL CONTROL MODE	p 12
> 5.5. ERRORS LOG AND TIME OF USE	p 12
> 5.6. FACTORY RESET	p 13
> 6. CONNECTING TO AN AUTOMATION SYSTEM (OPTION)	p 13
> 6.1. EXTERNAL CONTROL VIA RS-485	p 13
> 6.2. Using the Pump's Output Signal	p 14
> 7. PUMP MAINTENANCE	p 15
> 8. Drive Removal and Installation	p 17
> 9. ALARMS AND FAULT CODES	p 17
> 10. TROUBLESHOOTING	p 19

IMPORTANT SAFETY INSTRUCTIONS



IMPORTANT NOTICE

This guide provides installation and operation instructions for this pump. Consult Pentair with any questions regarding this equipment.

Attention Installer: This guide contains important information about the installation, operation and safe use of this product. This information should be given to the owner and/or operator of this equipment after installation or left on or near the pump.

Attention User: This manual contains important information that will help you in operating and maintaining this product. Please retain it for future reference.

READ AND FOLLOW ALL INSTRUCTIONS

SAVE THESE INSTRUCTIONS



This is the safety alert symbol. When you see this symbol on your system or in this manual, look for one of the following signal words and be alert to the potential for personal injury.



Warns about hazards that can cause death, serious personal injury, or major property damage if ignored.



Warns about hazards that may cause death, serious personal injury, or major property damage if ignored.



Warns about hazards that may or can cause minor personal injury or property damage if ignored.

NOTE

Indicates special instructions not related to hazards.

Carefully read and follow all safety instructions in this manual and on equipment. Keep safety labels in good condition; replace if missing or damaged.

When installing and using this electrical equipment, basic safety precautions should always be followed, include the following:



Do not permit children to use this product.



RISK OF ELECTRICAL SHOCK. The pump must only be connected to sockets that have been installed properly in accordance with the regulations and are protected with a FI-safety switch (residual-current device RCD, 30mA).



This unit must be connected only to a supply circuit that is protected by a ground-fault circuit-interrupter (RCD). Such a RCD should be provided by the installer and should be tested on a routine basis. To test the RCD, push the test button. The RCD should interrupt power. Push the reset button. Power should be restored. If the RCD fails to operate in this manner, the RCD is defective. If the RCD interrupts power to the pump without the test button being pushed, a ground current is flowing, indicating the possibility of an electric shock. Do not use this pump. Disconnect the pump and have the problem corrected by a qualified service representative before using.



This pump is for use with permanent swimming pools and may also be used with hot tubs and spas if so marked. Do not use with storable pools. A permanently-installed pool is constructed in or on the ground or in a building such that it cannot be readily disassembled for storage. A storable pool is constructed so that it is capable of being readily disassembled for storage and reassembled to its original integrity.

General Warnings

- Never open the inside of the drive motor enclosure. There is a capacitor bank that holds a 230 VAC charge even when there is no power to the unit
- The pump is not submersible. The pump is capable of high flow rates; use caution when installing and programming to limit pumps performance potential with old or questionable equipment.
- Code requirements for electrical connection differ from country to country, state to state, as well as local municipalities. Install equipment in accordance with IEC 60364 (Low-voltage electrical installations), IEC 60364-7-702 (Requirements for special installations or locations - Swimming pools and other basins) and all applicable local codes and ordinances.
- Before servicing the pump; switch OFF power to the pump by disconnecting the main circuit to the pump.
- This appliance is not intended for use by persons (including children) of reduced physical, sensory or mental capabilities, or lack of experience and knowledge, unless they have been given supervision or instruction concerning the use of the appliance by a person responsible for their safety.
- Children should not be allowed to play with the appliance.



FAILURE TO FOLLOW ALL INSTRUCTIONS AND WARNINGS CAN RESULT IN SERIOUS BODILY INJURY OR DEATH. THIS PUMP SHOULD BE INSTALLED AND SERVICED ONLY BY A QUALIFIED POOL SERVICE PROFESSIONAL. INSTALLERS, POOL OPERATORS AND OWNERS MUST READ THESE WARNINGS AND ALL INSTRUCTIONS IN THE OWNER'S MANUAL BEFORE USING THIS PUMP. THESE WARNINGS AND THE OWNER'S MANUAL MUST BE LEFT WITH THE POOL OWNER.



SUCTION ENTRAPMENT HAZARD: STAY OFF THE MAIN DRAIN AND AWAY FROM ALL SUCTION OUTLETS!



THIS PUMP PRODUCES HIGH LEVELS OF SUCTION AND CREATES A STRONG VACUUM AT THE MAIN DRAIN AT THE BOTTOM OF THE BODY OF WATER. THIS SUCTION IS SO STRONG THAT IT CAN TRAP ADULTS OR CHILDREN UNDER WATER IF THEY COME IN CLOSE PROXIMITY TO A DRAIN OR A LOOSE OR BROKEN DRAIN COVER OR GRATE.

THE USE OF UNAPPROVED COVERS OR ALLOWING USE OF THE POOL OR SPA WHEN COVERS ARE MISSING, CRACKED OR BROKEN CAN RESULT IN BODY OR LIMB ENTRAPMENT, HAIR ENTANGLEMENT, BODY ENTRAPMENT, Evisceration AND/OR DEATH.

The suction at a drain or outlet can cause:

Limb Entrapment: When a limb is sucked or inserted into an opening resulting in a mechanical bind or swelling. This hazard is present when a drain cover is missing, broken, loose, cracked or not properly secured.

Hair Entanglement: When the hair tangles or knots in the drain cover, trapping the swimmer underwater. This hazard is present when the flow rating of the cover is too small for the pump or pumps.

Body Entrapment: When a portion of the body is held against the drain cover trapping the swimmer underwater. This hazard is present when the drain cover is missing, broken or the cover flow rating is not high enough for the pump or pumps.

IMPORTANT SAFETY INSTRUCTIONS

Visceration/Disembowelment: When a person sits on an open pool (particularly a child wading pool) or spa outlet and suction is applied directly to the intestines, causing severe intestinal damage. This hazard is present when the drain cover is missing, loose, cracked, or not properly secured.

Mechanical Entrapment: When jewelry, swimsuit, hair decorations, finger, toe or knuckle is caught in an opening of an outlet or drain cover. This hazard is present when the drain cover is missing, broken, loose, cracked, or not properly secured.

NOTE: ALL SUCTION PLUMBING MUST BE INSTALLED IN ACCORDANCE WITH THE LATEST NATIONAL AND LOCAL CODES, STANDARDS AND GUIDELINES.

WARNING TO MINIMIZE THE RISK OF INJURY DUE TO SUCTION ENTRAPMENT HAZARD:

- A properly installed and secured ANSI/ASME A112.19.8 approved anti-entrapment suction cover must be used for each drain.
- Each suction cover must be installed at least three (3') feet apart, as measured from the nearest point to nearest point.
- Regularly inspect all covers for cracks, damage and advanced weathering.
- If a cover becomes loose, cracked, damaged, broken or is missing, replace with an appropriate certified cover.
- Replace drain covers as necessary. Drain covers deteriorate over time due to exposure to sunlight and weather.
- Avoid getting hair, limbs or body in close proximity to any suction cover, pool drain or outlet.
- Disable suction outlets or reconfigure into return inlets.

WARNING The pump can produce high levels of suction within the suction side of the plumbing system. These high levels of suction can pose a risk if a person comes within the close proximity of the suction openings. A person can be seriously injured by this high level of vacuum or may become trapped and drown. It is absolutely critical that the suction plumbing be installed in accordance with the latest national and local codes for swimming pools.

WARNING A clearly labeled emergency shut-off switch for the pump must be in an easily accessible, obvious place. Make sure users know where it is and how to use it in case of emergency.

For Installation of Electrical Controls at Equipment Pad (ON/OFF Switches, Timers and Automation Load Center)

CAUTION



Install all electrical controls at equipment pad, such as on/off switches, timers, and control systems, etc., to allow the operation (startup, shut-down, or servicing) of any pump or filter so the user does not place any portion of his/her body over or near the pump strainer lid, filter lid or valve closures. This installation should allow the user enough space to stand clear of the filter and pump during system start-up, shut down or servicing of the system filter.

DANGER HAZARDOUS PRESSURE: STAND CLEAR OF PUMP AND FILTER DURING START UP.



Circulation systems operate under high pressure. When any part of the circulating system (i.e. locking ring, pump, filter, valves, etc.) is serviced, air can enter the system and become pressurized. Pressurized air can cause the pump housing cover, filter lid, and valves to violently separate which can result in severe personal injury or death. Filter tank lid and strainer cover must be properly secured to prevent violent separation. Stand clear of all circulation system equipment when turning on or starting up pump.

Before servicing equipment, make note of the filter pressure. Be sure that all controls are set to ensure the system cannot inadvertently start during service. Turn off all power to the pump. **IMPORTANT: Place filter manual air relief valve in the open position and wait for all pressure in the system to be relieved.**

Before starting the system, fully open the manual air relief valve and place all system valves in the "open" position to allow water to flow freely from the tank and back to the tank. Stand clear of all equipment and start the pump. **IMPORTANT: Do not close filter manual air relief valve until all pressure has been discharged from the valve and a steady stream of water appears.** Observe filter pressure gauge and be sure it is not higher than the pre-service condition.

General Installation Information

All work must be performed by a qualified service professional, and must conform to all national, state, and local codes.

Install to provide drainage of compartment for electrical components.

These instructions contain information for a variety of pump models and therefore some instructions may not apply to a specific model. All models are intended for use in swimming pool applications. The pump will function correctly only if it is properly sized to the specific application and properly installed.

WARNING Pumps improperly sized or installed or used in applications other than for which the pump was intended can result in severe personal injury or death. These risks may include but not be limited to electric shock, fire, flooding, suction entrapment or severe injury or property damage caused by a structural failure of the pump or other system component.

WARNING The pump can produce high levels of suction within the suction side of the plumbing system. These high levels of suction can pose a risk if a person comes within the close proximity of the suction openings. A person can be seriously injured by this high level of vacuum or may become trapped and drown. It is absolutely critical that the suction plumbing be installed in accordance with the latest national and local codes for swimming pools.

INTRODUCTION

Pentair variable speed pumps equipped with VSe drive can be programmed to run at speeds over set periods of time. This provides maximum operating efficiency and energy conservation for a variety of inground pools.

All Pentair pumps incorporate innovative hydraulic engineering that has been refined for over 40 years. Compact, rugged, and easy to maintain, this pump will deliver years of reliable service.

- The pump can operate at a percentage of maximum motor speed
- Up to 3 customizable programs that can be set for constant speed in schedule modes.
- Programmable priming cycle with automatic
- Compatible with most cleaning systems, filters, and jet action spas.

CAUTION

Some speeds might cause resonance and noise coming from the pump in specific installations. This can be solved by slightly modifying the speed.

Motor Features

- Induction, totally enclosed fan-cooled (TEFC) motor.
- Low noise

Drive Features

The pump drive is designed to produce maximum motor operational efficiency. The drive controls the motor's rotational speed by controlling the frequency of the supplied current. It also protects the motor and pump from operating outside of their intended operating parameters.

The pump's drive controls the speed settings as well as run durations. The pump can operate at speeds ranging between 600 and 3000 RPM (+50 RPM increment) and will operate at 230VAC at either 50 or 60Hz input frequency.

- Simple user interface
- Onboard time of day schedule
- Adjustable priming mode
- Programmable quick clean mode
- Diagnostic alarm display and retention
- Dry Run Detection
- Overcurrent detection

• 1. ELECTRICAL INSTALLATION

WARNING



RISK OF ELECTRICAL SHOCK OR ELECTROCUTION. This pump must be installed by a licensed or certified electrician or a qualified service professional in accordance with the National Electrical Code and all applicable local codes and ordinances. Improper installation will create an electrical hazard which could result in death or serious injury to users, installers, or others due to electrical shock, and may also cause damage to property.

Always disconnect power to the pump at the circuit breaker before servicing the pump. Failure to do so could result in death or serious injury to service people, users or others due to electric shock.

Read all servicing instructions before working on the pump.

Note: ALWAYS reinstall the wiring cover onto the field wiring compartment when leaving the pump unsupervised. This will prevent foreign matter (i.e. water, dust, etc.) from accumulating in the drive.

Note: When connecting the pump to an automation system, continuous power must be supplied to the pump by connecting it directly to the circuit breaker. When using an automation system, be sure that no other lights or appliances are on the same circuit.

Circuit Protection: Require RCD protection device, in accordance with IEC 60364 (Low-voltage electrical installations), IEC 60364-7-702 (Requirements for special installations or locations - Swimming pools and other basins) and local electrical codes. The drive will operate on 2-Phase Line-Neutral-Ground electrical systems.

Wiring

1. Ensure all appropriate electrical breakers and switches are turned off before wiring the motor.

⚠ WARNING **STORED CHARGE** - Wait at least sixty (60) seconds before servicing.

2. Ensure the supply voltage meets the requirements listed on the motor nameplate. If these requirements are not met, permanent motor damage may occur.
3. The pump should be permanently connected to its own independent RCD-protected circuit.
4. For wiring sizes and general electrical guidelines, please follow the specifications defined in IEC 60364 (Low-voltage electrical installations), IEC 60364-7-702 (Requirements for special installations or locations - Swimming pools and other basins) and any local codes as required.

5. Use strain reliefs and ensure all electrical connections are clean and tight.

Note: Any unused conduit openings should be sealed with the provided conduit plugs.

6. Cut all wires and conductors to appropriate lengths to help prevent conductors from arcing or overlapping once connected.

Grounding - only for pumps supplied without power cable

1. Permanently ground the drive using the green Ground Wire Screw and ensure the ground wire is connected to an electrical service ground.

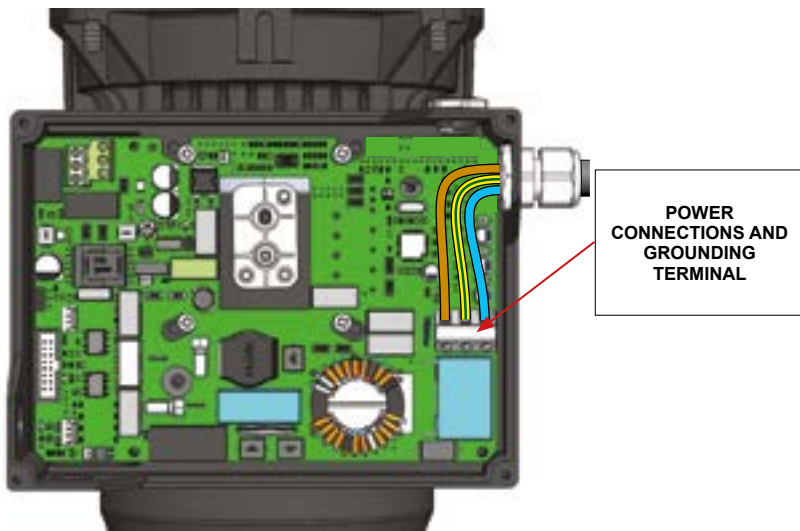

Figure 1

2. CONTROL PANEL OVERVIEW

Before operating the pump for the first time, the pump's internal clock must be programmed.

Refer to *Setting the Clock* (page 11).

The pump can be programmed and controlled from the drive keypad. Pump features and settings are also accessed using this keypad.

Note: Functionality may vary based on other active features such as External Control Only Mode

Note: Always close the keypad cover after use. This will prevent damage to the keypad and other drive components.

⚠ CAUTION Only press keypad buttons with your fingers. Using screwdrivers, pen or other tools to program the pump will damage the keypad.

⚠ WARNING If power is connected to the pump motor, pressing any of the following buttons referred to in this section could result in the motor starting. Failure to recognize this could result in personal injury or damage to equipment.

2.1. DISPLAY

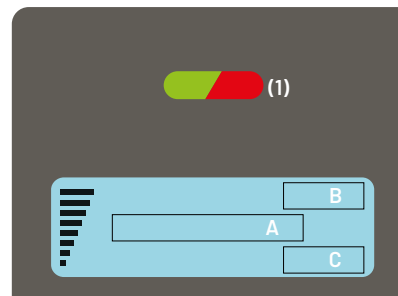

Figure 2

1. **STATUS LED** – When active (green), indicates that the pump is in ACTIVE status, either running a program or in stand-by waiting for scheduled start. RUN LED goes off when entering STOP status (press START/STOP button). Display will show a STOP indicator. STATUS LED is active (red) when pump is in a fault condition. Please refer to Errors and Alarms (page 17) for troubleshooting
2. **“A” FIELD** – Visualize pump parameter: speed (RPM), Power consumption (Watt), Time (HH:MM), TIME LEFT to next program (HH:MM). Press SET to scroll through the different parameter. When pump is in STAND-BY mode, only Clock and Time to next program are displayed.
3. **“B” FIELD** – Display unit of measure relative to A FIELD.
4. **“C” FIELD** – Display program currently run.

2.2. KEYPAD NAVIGATION

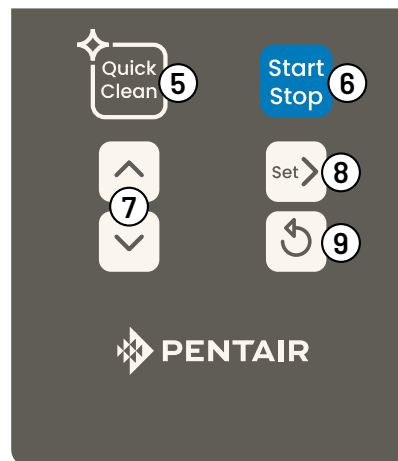

Figure 3

5. **Quick Clean Button** - Used to run a selected speed and duration programmed for Quick Clean (default: 2 hours at 2600rpm)
6. **Start/Stop Button** - Used to Start and Stop the pump. When the pump is stopped and the RUN LED is not illuminated, the pump is unable to run from any type of input.
7. **“+” and “-” Arrows** - Used to make on screen adjustments to the pump settings. The “+” arrow increases the value of a given setting, while “-” decreases the value of a given setting. Pressing and holding down either arrow button will increase or decrease the incremental changes faster.
8. **SET Button** - When pump in active status, the button is used to toggle between the different available display modes. When pump is in STOP status, SET button is used to enter the menu and to save settings.
9. **ESC button** - When pump is in STOP status, it is used to exit out of the menu and to exit sub-menus without saving.

3. PUMP INSTALLATION

Only a qualified plumbing professional should install the pump. Refer to IMPORTANT SAFETY INSTRUCTIONS, for additional installation and safety information. Note: The pump should not be connected in series with other pumps.

3.1. LOCATION

Note: Do not install this pump within an outer enclosure or beneath the skirt of a hot tub or spa unless marked accordingly.

Note: Ensure that the pump is mechanically secured to the equipment pad. Do not install this pump within an outer enclosure or beneath the skirt of a hot tub or spa unless marked accordingly.

Be sure the pump location meets the following requirements:

Install the pump as close to the pool or spa as possible. To reduce friction loss and improve efficiency, use short, direct suction and return piping.

- Install the pump a minimum of 1.5 m from the inside wall of the pool.
- Install the pump a minimum of 0.9 m from a heater outlet.
- Do not install the pump more than 3.1 m above the pool water level.
- Provide at least 7.6 cm of side and rear clearance for motor disassembly and removal.
- Provide at least 15.2 cm of top clearance for drive disassembly and removal.
- Install the pump in a well ventilated location protected from excessive moisture, dirt and heat (i.e., rain gutter downspouts, sprinklers, etc.)

3.2. PLUMBING AND FITTINGS

- Provided union kit allows for easy plumbing to 50mm PVC pipes.
- For improved plumbing a larger pipe size should be used.
- To reduce friction loss and improve efficiency, short and direct suction and return lines are best.
- Suction line diameter should be the same or larger than the return line diameter.
- Do not install 90° elbows directly into the pump inlet or outlet.
- Valves, elbows or tees installed in the suction line should be no less than 5 times the suction pipe diameter from the pump inlet.

3.3. VALVES

- Flooded suction systems should have valves installed in both the pump suction and return lines. This allows the pump to be isolated during routine maintenance.
- Install a check valve in the return line when using this pump for any application where there is significant height to the plumbing after the pump.
- Install check valves when plumbing in parallel with another pump. This helps prevent reverse rotation of the impeller and motor.

4. OPERATION

Before operating the pump for the first time, the pump's internal clock and operational schedules must be programmed by following the steps in this manual. Refer to Setting the Clock (page 11) for instructions regarding the programming of this pump for scheduled operation

4.1. START-UP:

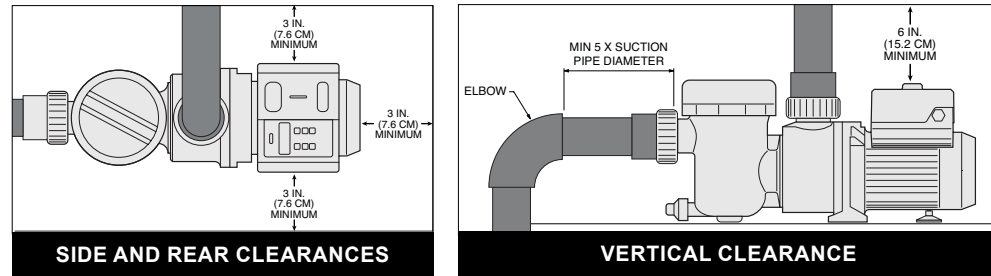

- When pump is plugged for the first time after production or after a factory reset (page 13)
- When power is first connected to the pump the clock will blink to indicate that it has not been set
- When connected to power for first time, drive is in STOP status
- When in STOP, STATUS LED are off
- In order to activate the pump, user will have to press START/STOP button.
- When status is active, green LED is ON.

4.2. PRIMING THE PUMP:



This pump is shipped with Priming mode ENABLED. The pump will ramp to 3000 RPM when the pump is initially started.

Before turning the pump ON:

1. Open filter air relief valve.
2. Open necessary valves.
3. Ensure return line is completely open and clear of any blockages.
4. Ensure pump is filled with water.
5. Stand clear of the filter or other pressurized vessels.

This pump is shipped with Priming ENABLED. Unless the priming settings are changed, the pump will speed up to the maximum speed when the pump is powered on for the first time, and the ON/STOP button is pressed. The pump must be filled with water and primed before initial startup and after servicing. To avoid permanent damage to the pump, follow the instructions below.



Do NOT run the pump dry, the shaft seal will be damaged and the pump will start leaking. If this occurs, the damaged seal must be replaced. ALWAYS maintain proper water level in your pool (half way up skimmer opening). If the water level falls below the skimmer opening, the pump will draw air through the skimmer, losing the prime and causing the pump to run dry, resulting in a damaged seal. Continued operation in this manner could cause a loss of pressure, resulting in damage to the pump body, impeller and seal and may cause property and personal injury.



Do NOT run the pump dry. If the pump is run dry, the shaft seal will be damaged and the pump will start leaking. If this occurs, the damaged seal must be replaced.



ALWAYS maintain proper water level in your pool (half way up skimmer opening). If the water level falls below the skimmer opening, the pump will draw air through the skimmer, losing the prime and causing the pump to run dry, resulting in a damaged seal. Continued operation in this manner could cause a loss of pressure, resulting in damage to the pump case, impeller and seal and may cause property and personal injury.

TO PRIME THE PUMP:

1. Press START/STOP to stop the pump and disconnect all power to the pump at the circuit breaker.
 2. Close all valves in suction and return lines
 3. Open the filter's air relief valve and relieve all pressure from the filtration system.
 4. Turn the Strainer Pot Lid counter-clockwise and remove it from the pump.
 5. Fill the strainer pot up to the Suction Port with water.
 6. Place the lid onto the strainer pot and tighten until the lid handles are perpendicular to the suction port.
- Note:** Ensure the lid O-ring is properly seated and is not being pinched between the lid and strainer pot.
7. Open all valves in suction and return lines.
 8. Open the filter's air relief valve and stand clear of the filter.
 9. Reestablish power to the pump at the circuit breaker.
 10. Press ON/STOP to start the pump. The pump will begin to prime (if enabled) and ramp up to the programmed priming speed.
 11. When a steady stream of water appears from the air relief valve, close the valve.
 12. Do not allow your pump to run longer than 30 minutes without successfully priming. If the pump does not prime, check your priming settings or refer to TROUBLESHOOTING, page 19.

4.3. USING THE DEFAULT SCHEDULE

The default schedule is designed to provide enough daily turnover to service a typical pool. See Table 1 for default schedule.

	Duration (Hours)	Speed (RPM)
SPEED 1	2	3000
SPEED 2	10	1400
SPEED 3	2	2200

The default schedule will operate as follows:

- SPEED 1 will begin at 8:00am (default schedule) and run at 3000 RPM for a duration of 2 hours.
- SPEED 2 will begin immediately after SPEED 1 completes. Default SPEED 2 runs at 1400 RPM for 10 hours.
- SPEED 3 will begin immediately after SPEED 2 completes. Default SPEED 3 runs at 2200 RPM for 2 hours.
- After SPEED 3 runtime has ended, the pump will enter a stationary/paused state for the next 10 hours.
- The pump will restart at 8:00am the next morning and cycle through the default schedule again. The pump will continue to run in this manner until a custom schedule is programmed.

Note: The Start/Stop button must be pressed, and the green LED lit, for the pump to run.

4.4. OPERATING THE PUMP WHILE RUNNING

- Pressing the **SET** button will cycle through the current parameters:
- Speed — current run speed in RPM
- Time — current time of day
- Duration — amount of time remaining at the current run speed
- Watts — amount of watts currently being consumed

Pressing **Quick Clean** while the pump is running will act as a temporary override. The pump will run the speed and duration programmed for that button. Once completed the pump will return to the appropriate point in the programmed schedule.

Note: if you adjust the speeds of the schedule while the pump is running (by pressing “+” and “-“), the pump will run the adjusted speed for the rest of the current duration, but it will not save the adjustments.



If power is connected to the pump, pressing any of the following buttons referred to in this section could result in the motor starting. Failure to recognize this could result in personal injury or damage to equipment.

If the pump status is Active (STATUS LED green) but in Stand-by (schedule), by pressing “+” buttons pump will go from “hold” condition to Priming (“+”) SPEED1 (“+”) SPEED2 (“+”) SPEED3. By pressing “-“ user can go back to stand-by condition.

Note: If the speed is set on SPEED1, the pump will run SPEED1, then SPEED2 and SPEED3 until the Default schedule starts. This act as a temporary override until next scheduled program start.

4.5. QUICK CLEAN

Press **QUICK CLEAN** while pump is active (STATUS LED green) to override schedule. Pump will run at 2600 rpm speed for 2 hours duration.

Quick clean speed and duration can be customised, see «too program a custom schedule», page 11.

During a Quick Clean cycle, pressing the “+” or “-“ buttons will temporarily change the speed.

A Quick Clean cycle can be stopped early by pressing and holding the **QUICK CLEAN** button for 3 seconds. The pump will return to the appropriate point in the programmed schedule.

A pump connected via digital inputs can still run its **QUICK CLEAN** program.

At the end of **QUICK CLEAN** cycle, pump will return to standard schedule

4.6. PRIMING

Priming will automatically run when the pump is started (example: at the start of daily schedule, when SPEED1 starts)

Default Priming Speed is 3000 RPM, and will last for 5 minutes. The drive will display PRI (bottom right) and time left in the middle.

During the priming sequence, priming speed can be adjusted between xxxx and 3000 RPM using the “+” and “-“ arrows. The change is temporary.

If the pump is in EXTERNAL CONTROL MODE, priming will automatically run any time the pump move from a standby condition to a speed condition (i.e. a speed input is received).

Priming time can change based on local environmental conditions such as water temperature, atmospheric pressure, and your pool's water level. All of these things should be taken into consideration when setting the priming speed. Test and verify priming speeds more than once, letting the water drain from the system in between each test.

Note: To prevent air from entering the system, the pump strainer pot should always be filled with water up to the bottom of the suction port.

5. USER MENU

To customize your pump's schedule and default parameters, the pump must be stopped. Ensure that the green LED is not illuminated. If STATUS LED is green, press **START/STOP**. To enter the user menu, press the **“SET”** button.

5.1. SETTING THE CLOCK

When power is first connected to the pump after production, the clock will blink to indicate that it has not been set. In order to set the clock:

1. Use “ (+) ” and “ (-) ” to navigate to “CLOCK” menu
2. Press **SET** to enter the sub-menu
3. Use “ (+) ” and “ (-) ” to choose between a 12 or 24 hour time format.
4. Press **SET** to advance.
5. Use “+” and “-“ to program the Hour (XX:00)
6. Press **SET** to advance.
7. Use “+” and “-“ to program the Minutes(09:xx)

NOTE: In the 12 hour time format AM/PM will display in the bottom right corner.

8. Press **SET** to advance. ENABLE: YES will display.
9. Use the “+” and “-“ buttons to choose between time clock On (YES) or Off (NO)

NOTE: Time clock is On as default. If clock is de-activated the pump will start from speed 1, whenever the pump is powered up. The pump will then proceed to speed 2, after the programmed duration for speed 1 has elapsed and so on for speed 3. This is the recommended setting for pumps connected to an external timer which acts as power switch.

10. Press **SET** to save and exit the menu.

NOTE: During a power outage, the drive will retain the clock setting for as long as 30 minutes. If the power is out longer than 30 minutes, the clock will have to be re-set. If the drive has lost the user set time, the clock will continuously blink until the time is reset. Note: When power is returned to the pump after a prolonged outage (1+ hours) the clock will automatically set itself to the Speed 1 start time, blink and advance. The pump will also run the associated schedule from that start time. If pump was in STOP status when power outage occurred, pump will retain the STOP status.

NOTE: Real time clock battery (capacitor) need the drive to be powered for at least 30 mins in order to guarantee 30 minutes clock retention during a power outage.

NOTE: Real time clock battery (capacitor) may deteriorate over time resulting in shorter clock retention.

5.2. TO PROGRAM A CUSTOM SCHEDULE

NOTE: all steps must be completed in order for the changes to be successfully applied. The “ESC” button can be pressed to exit the procedure without saving.

1. Use “ (+) ” and “ (-) ” to navigate to “PROGRAM” menu
2. Press **SET** to enter the sub-menu
3. Use “+” and “-“ to adjust the speed in RPM for SPEED 1.
4. Press **SET**. SPEED 1 start time will display.
5. Use “+” and “-“ to adjust the SPEED 1 start time (+-15 minutes)
6. Press **SET**. SPEED 1 duration will display
7. Use “+” and “-“ to adjust the SPEED 1 duration in hours and minutes (increment of +-15 mins)

NOTE: SPEED 1 has a minimum duration of 15min.

8. Press **SET**. SPEED 2 will appear.
9. Use “+” and “-“ to adjust the speed in RPM for SPEED 2.
10. Press **“SET”**. SPEED 2 duration will display.
11. Use “+” and “-“ to adjust the SPEED 2 duration in hours and minutes (increment of +-15 mins)

Note: SPEEDs 2 and 3 do not have a start time, as they begin immediately after the previous SPEED finishes

12. Repeat SPEED 2 steps above to program SPEED 3.

Note: The duration allowed for SPEED 3 will be limited to the remaining time in a 24 hour day. Any time in the 24 hour day not programmed into SPEEDs 1-3, the pump will remain in a stationary state. [SPEED 1 + SPEED 2 + SPEED 3 < 24 Hours]

13. Press **SET**. QUICK CLEAN speed will display.

14. Use “+” and “-“ to adjust the speed in RPM for QUICK CLEAN.

15. Press **SET**. QUICK CLEAN duration will display.
16. Use “+” and “-” to adjust the QUICK CLEAN duration in hours and minutes (increment of +-15 mins)
17. Press **SET**. PRI ON will appear on screen. Press “+” or “-“ to change it to PRI OFF. PRI OFF mean priming is disabled.
18. Press **SET**.

If “PRI ON”:

- Use “+” and “-” to adjust the speed in RPM for Priming.
- Press **SET**. PRIMING duration will display.
- Use “+” and “-” to adjust the PRIMING duration in minutes (increment of +-1 mins, minimum of 1 minutes, maximum of 15 minutes)
- Press **SET** to save. Screen goes back to main menu.

If “PRI OFF”:

- Press **SET** to save. Screen goes back to main menu.

5.3. LANGUAGE SELECTION

VSe drive can be operated in 7 languages: EN, IT, FR, NL, DE, ES, PT.

1. Use “ (+) ” and “ (-) ” to navigate to “LANGUAGE” menu
2. Press **SET** to enter
3. Use “ (+) ” and “ (-) ” to select the desired language
4. Press **SET** to save. Screen goes back to main menu.

5.4. EXTERNAL CONTROL MODE

External Control Only mode will only allow the pump to run from external controls/inputs. When this mode is active the programmed pump schedule is deactivated, and user speed requests from the keypad will not be accepted.

NOTE: A pump connected via digital inputs can still run its **QUICK CLEAN** program. **QUICK CLEAN** will temporarily override external input.

TO ENABLE/DISABLE EXTERNAL CONTROL ONLY MODE:

1. Use “ (+) ” and “ (-) ” to navigate to “CONTROL MODE” menu
2. Press **SET** to enter
3. Use “ (+) ” and “ (-) ” to select INT(default keyboard control) or EXT (external control)
4. Press “**SET**” to save. Screen goes back to default view (“home”).

5.5. Errors log and time of use

1. Use “ (+) ” and “ (-) ” to navigate to “Error log” menu
2. Press **SET** to enter
3. Use “ (+) ” and “ (-) ” to navigate the “Error log” menu

NOTE: Error log menu display total hours run by the pump since production, error codes occurred and time at which errors occurred, see Figure 2. For a detailed list of errors and alarms, see page 18.

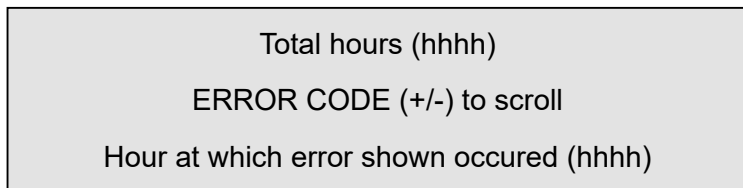

Figure 4

5.6. FACTORY RESET

The drive can be reset to factory settings if necessary. A Factory Reset will erase all programmed settings and schedules, except for the time of day and total hours of use of the pump. Be sure that it is necessary before performing a Factory Reset, as the results are immediate.

TO PERFORM A FACTORY RESET:

1. Use “ (+) ” and “ (-) ” to navigate to “Factory Reset” menu
2. Press **SET** for 3 seconds to enter
3. Use “ (+) ” and “ (-) ” to select YES (Factory reset) or EXIT
4. Press **SET** for 3 seconds to confirm

«Loading» will display and then pump will return to STOP state if factory reset is successful

NOTE: The pump has returned to default settings The pump must be turned back on with the Start/Stop button before it will run again. The pump will run the programmed schedule upon initial start-up.

6. CONNECTING TO AN AUTOMATION SYSTEM (OPTION)

All VSe mounted pumps can be controlled via external input signal.

Use a 0.25 mm2 four-conductor cable to connect an automation system to the pump.



WARNING **RISK OF ELECTRICAL SHOCK OR ELECTROCUTION.** Always disconnect power to the pump at the circuit breaker before servicing the pump. Failure to do so could result in death or serious injury to service people, users or others due to electric shock.
Read all servicing instructions before working on the pump.

Refer to the automation system manual for further details on connecting your pump to a specific automation system.

6.1. External Control via RS-485

These pumps can be controlled from certain Pentair control systems, via an RS-485 signal.

Refer to External Control Mode (page 12) for instructions regarding setting the pump in external control mode.

Note: If the pump has been stopped via the START/STOP button (STATUS led is off), START/STOP must be pressed again before the pump will operate. When a low voltage signal is received by a control board digital input, the pump will run the program set to that specific digital input.

Only the GREEN and YELLOW conductors will be used to wire the pump for external control via RS-485. See Figure 5.

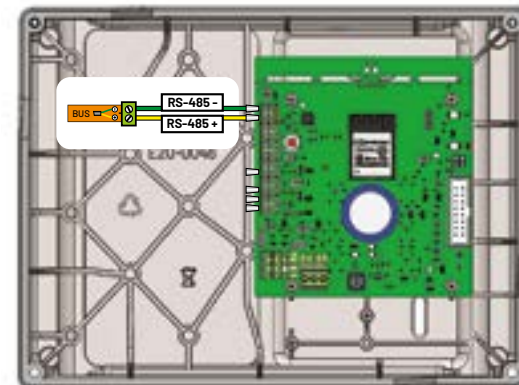

Figure 5

6.2. Using the Pump's Output Signal

The VSe board provides a +3.3V Output Signal that can be used to trigger its own Digital Inputs. This output signal is the recommended input for Speed Digital Inputs. The output signal will need to be switched via an External Control (i.e. automation relay, external system componentswitch) to activate the desired speed program.

WARNING **STORED CHARGE** - Wait at least sixty (60) seconds before servicing.

Route the communication cable from the VSe communication board to the control system wiring compartment, as represented in Figure 6 and Figure 7.

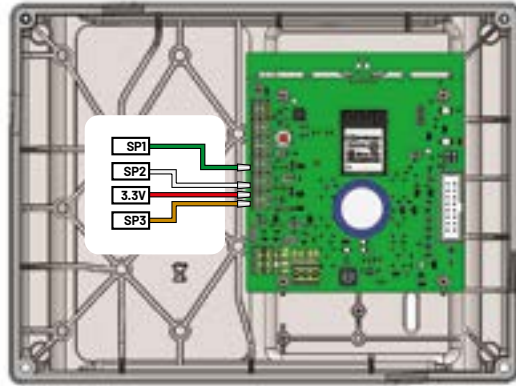

Figure 6

Ensure the cable reaches all necessary terminals and cut to the necessary length.

Strip all 0.25 mm² conductors by 13 mm.

Note: Unused conductors should be cut off and terminated according to local and national electrical codes.

When ready to start the pump, place the pump into External Control Only mode. Refer to External Control Only Mode on page 12.

Note: If the pump has been stopped via the START/STOP button (RUN led is off), START/STOP must be pressed again before the pump will operate. When a low voltage signal is received by a control board digital input, the pump will run the program set to that specific digital input.

Note: If multiple external input triggers are received, programs will follow the following priority SPEED3>2>1

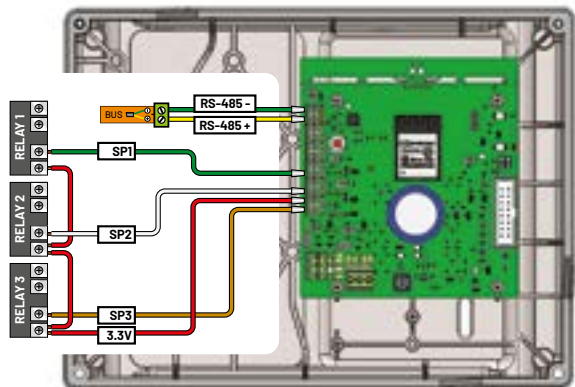

Figure 7

7. PUMP MAINTENANCE

WARNING Always disconnect power to the pump at the circuit breaker and relieve pressure in the filtration system before servicing the pump. Failure to do so could result in death or serious injury to serviceman, pool users or others due to electric shock. Do NOT attempt to adjust or service without consulting your dealer or a qualified pool technician. Read the entire Installation and Maintenance Guide before attempting to use, service, or adjust the pool filtering system or heater.

WARNING Do NOT open the pump strainer pot if pump fails to prime or if pump has been operating without water in the strainer pot. Pumps operated in these circumstances may experience a build up of vapor pressure and may contain scalding hot water. Opening the pump may cause serious personal injury. In order to avoid the possibility of personal injury, ensure the suction and return valves are open and strainer pot temperature is cool to touch, then open with extreme caution.

CAUTION To prevent damage to the pump and for proper operation of the system, clean pump strainer and skimmer baskets regularly.

Cleaning the Pump Strainer Basket

The strainer pot is located at the front of the pump and houses the pump strainer basket.

The strainer basket can be viewed through the strainer pot lid and should be visually inspected at least once a week. Regularly emptying and cleaning the strainer basket will lead to higher filter and heater efficiency and prevent unnecessary stress on the pump motor.

TO CLEAN THE STRAINER BASKET:

1. Press ON/STOP to stop the pump and disconnect all power to the pump at the circuit breaker.
 2. Open the filter's air relief valve and relieve all pressure from the filtration system.
 3. Turn the strainer pot lid counter-clockwise and remove it from the pump.
 4. Remove the strainer basket and rinse out all debris. Replace the basket if it is cracked or damaged.
 5. Place the strainer basket back into the strainer pot. Ensure the opening in the front of the strainer basket is aligned with the suction outlet.
 6. Fill the strainer pot up to the suction port with water.
 7. Clean the lid O-ring and sealing surface of the strainer pot.
- Note:** It is important to keep the lid O-ring clean.
8. Reinstall the lid by placing it onto the strainer pot and tightening clockwise until the lid handles are perpendicular to the suction port.
- Note:** Ensure the lid O-ring is properly placed and is not being pinched between the lid and strainer pot.
9. Open the filter air relief valve and stand clear of the filter.
 10. Reestablish power to the pump at the circuit breaker and start the pump.
 11. When a steady stream of water flows from the filter air relief valve, close the valve.

WARNING THIS SYSTEM OPERATES UNDER HIGH PRESSURE. When any part of the circulating system is serviced, air can enter the system and become pressurized. Pressurized air can cause the lid to separate which can result in serious injury, death, or property damage. To avoid this potential hazard, follow above instructions.



Winterizing

You are responsible for determining when freezing conditions may occur. If freezing conditions are expected, take the following steps to reduce the risk of freeze damage. **Freeze damage is not covered under warranty.**

In mild climate areas, when temporary freezing conditions may occur, run your filtering equipment all night to prevent freezing.

TO PREVENT FREEZE DAMAGE:

1. Press **ON/STOP** to stop the pump and disconnect all power to the pump at the circuit breaker.
2. Open the filter's air relief valve and relieve all pressure from the filtration system.
3. Remove both drain plugs from the bottom of the strainer pot and drain the pump. Store the plugs in the strainer basket.
4. Cover the motor to protect it from severe rain, snow and ice.

Note: Do not wrap motor with plastic or other air tight materials during winter storage. Never cover the motor when operating or expecting operation

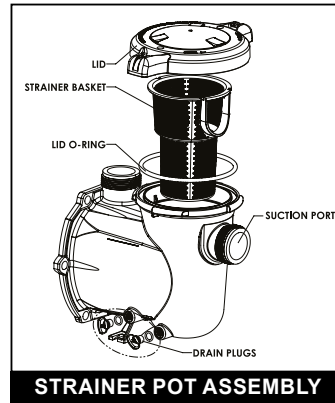

WARNING Always disconnect power to the pump at the circuit breaker before servicing the pump. Failure to do so could result in death or serious injury to serviceman, pool users or others due to electric shock. Do NOT attempt to adjust or service without consulting your dealer or a qualified pool technician. Read the entire Installation and Maintenance Guide before attempting to use, service, or adjust the pool filtering system or heater.

WARNING Do NOT open the pump strainer pot if pump fails to prime or if pump has been operating without water in the strainer pot. Pumps operated in these circumstances may experience a build up of vapor pressure and may contain scalding hot water. Opening the pump may cause serious personal injury. In order to avoid the possibility of personal injury, ensure the suction and return valves are open and strainer pot temperature is cool to touch, then open with extreme caution.

CAUTION Be sure not to scratch or mar the polished shaft seal faces; seal will leak if faces are damaged. The polished and lapped faces of the seal could be damaged if not handled with care.

Motor and Drive Care

Protect from heat

1. Shade the motor from the sun.
2. Any enclosure must be well ventilated to prevent overheating.
3. Provide ample cross ventilation.
4. Maintain a minimum clearance of 3-inches (7.6 cm) behind the motor fan to allow proper circulation and pump maintenance.

Protect against dirt and chemicals

1. Protect from any foreign matter.
2. Do not store (or spill) chemicals on or near the motor.
3. Avoid sweeping or stirring up dust near the motor while it is operating.
4. If a motor has been damaged by dirt it may void the motor warranty.
5. Periodically check for debris under the motor shrouds and clean it out. Refer to Disassembly, page 16.

Protect against moisture

1. Protect from continuous splashing or continuous sprayed water.
2. Protect from extreme weather such as flooding.
3. If motor internals have become wet - let it dry before operating. Do not allow the pump to operate if it has been flooded.
4. If a motor has been damaged by water it may void the motor warranty.
5. If the optional drive-mounted touchscreen is installed, ensure the cover is closed when not in use.

8. Drive Removal and Installation

WARNING To avoid dangerous or fatal electrical shock hazard, switch OFF power to motor before working on pump or motor.

WARNING FIRE AND BURN HAZARD. The pump motor may run at a high temperatures. To reduce the risk of fire, do NOT allow leaves, debris, or foreign matter to collect around the pump motor. To avoid burns when handling the motor, shut off the motor and allow it to cool for 20 minutes before servicing. The pump provides an automatic internal cutoff switch to protect the motor from heat damage during operation.

CAUTION To avoid electrical hazard, do NOT remove the four torx-head screws from the drive.

TO DISASSEMBLE AND REMOVE THE DRIVE:

1. Press **START/STOP** to stop the pump and disconnect all power to the pump at the circuit breaker.
2. Remove the 4 rubber cover at corner and loosen the four captive Phillips-head Top Cover Screws. Remove the Top Cover from the Drive.

3. Disconnect flat cable to separate top cover from drive power board

IF YOU NEED TO REMOVE POWER BOARD:

4. Disconnect main power wiring
5. Remove the four Phillips-head Drive Screws.
6. Disconnect the motor to drive wiring.
7. Gently separate the Drive from the Motor/ Hydraulic Assembly and place it aside.

9. ALARMS AND FAULT CODES

If an alarm is triggered the STATUS LED will turn RED and the screen will display a STATUS code text. Disconnect power to the pump and wait until the LEDs have all turned off, then reconnect power. If the error continues to appear after power is reconnected, proper troubleshooting will be required. Use the error description table below to begin troubleshooting.

MESS. DISPLAY	DESCRIPTION	ACTION
E00	No event	The error log appears when no errors have been signalled
E01	Communication error.	This error condition occurs when the control board cannot communicate with the power part. "Cut the power off and wait until the STATUS Led switches off and after which turn power back on. If the error condition occurs again, contact your pool professional."
E04	Generic error	"This error occurs in the presence of: Internal module error, Overheating of the power module, Pump failure" "Press the START/STOP button to attempt to exit this condition. In case of a persistent error, contact your pool professional."
E07 / E21	Over current error.	"This error occurs when the current absorbed by the module is greater than a threshold. This condition can be caused by blockages or debris build-up inside the pump. Note: over-current is detected during priming only. If priming is de-activated, this protection is de-activated." "Cut off the power supply and wait for the STATUS Led to switch off. Check the pump freely rotates and if necessary remove foreign bodies that block correct functioning. Turn power back on. If the error persists, contact your pool professional."
E12 / E24	Dry run alarm	"This condition occurs when the drive detects no water in the pump. Note: dry run is detected during priming only. If priming is de-activated, this protection is de-activated." "Check the water level in the pump. Press the button START/STOP to manually restart the system."

10. TROUBLESHOOTING

Use the following troubleshooting information to resolve possible problems with your pump.



WARNING Always disconnect power to the pump at the circuit breaker before servicing the pump. Failure to do so could result in death or serious injury to serviceman, pool users or others due to electric shock. Do NOT attempt to adjust or service without consulting your dealer or a qualified pool technician. Read the entire Installation and Maintenance Guide before attempting to use, service, or adjust the pool filtering system or heater.

PROBLEM	POSSIBLE	CORRECTIVE ACTIONS
Priming Issue	Air leak in suction	<ol style="list-style-type: none"> 1. Check suction piping and suction valve seals. 2. Check pool water level and ensure the skimmer is not drawing in air. 3. Check and clean the pump strainer pot lid o-ring
	Not enough water in strainer pot	Fill the strainer pot up to the suction port with water
	Priming speed or range too low.	Adjust priming parameters/settings (speed, duration, until the pump consistently primes, refer to
Reduced Capacity and/or Head	Clogged pump strainer basket	Clean the pump strainer basket.
	Air pockets or leaks in suction line	Inspect all piping and seals in the suction line.
	Clogged impeller	Disassemble the pump and remove debris from the impeller.
	Pump not running required speed	Check the pump drive interface for alerts or warnings.
Pump Runs then Stops	Over current FAULT	Disassemble the pump and check rotating parts for blockages or debris build-up. Clean if necessary
Pump is Noisy or Operating Loudly.	Debris in contact with cooling fan	Ensure the fan guard is clean. Use compressed air to remove any dirt, debris or blockages
	Clogged impeller	Disassemble the pump and remove debris from the impeller.
	Too much debris in strainer basket causing cavitation	Clean the pump strainer basket.
	Motor speed too high	Consider reducing the speed if possible.
Pump is Leaking (from Strainer Pot - Seal Plate Joint)		<ol style="list-style-type: none"> 1. Ensure the seal plate O-ring is not pinched between the seal plate and strainer pot. 2. Tighten the bolts joining the strainer pot and the seal plate. 3. If leak persists, disassemble the pump. Inspect all O-rings and seals for damage or debris build-up. Replace or clean the seals if necessary.
Pump is Leaking (from Strainer Pot Lid)		<ol style="list-style-type: none"> 1. Ensure the strainer pot lid is installed correctly (lid handles are perpendicular to the suction port) and is compressing the strainer pot lid O-ring. 2. Refer to Cleaning the Pump Strainer Basket on page 14 and remove the strainer pot lid. Inspect the strainer pot lid O-ring for damage or debris build-up. Replace or clean the O-ring if necessary
Pump is Leaking (from Underneath Motor)		Disassemble the pump and inspect the shaft seal. The shaft seal is a wearable part and will need to be replaced after prolonged operation.



Pentair International SARL

Ave. de Sévelin 20, CH-1004 - LAUSANNE, Switzerland

All indicated Pentair trademarks and logos are property of Pentair. Third party registered and unregistered trademarks and logos are the property of their respective owners.
© 2023 Pentair. All rights reserved.

Ave. de Sévelin 20, CH-1004 - LAUSANNE, Suisse

Toutes les marques et tous les logos indiqués sont la propriété de Pentair. Les logos et marques déposées ou non de tierces parties sont la propriété de leurs propriétaires respectifs.
© 2023 Pentair, tous droits réservés.

Ave. de Sévelin 20, CH-1004 - LAUSANNE, Switzerland

Alle vermeldte Pentair-handelsmerken en -logo's zijn het eigendom van Pentair. Alle andere geregistreerde en niet-geregistreerde handelsmerken en logo's zijn het eigendom van hun respectieve eigenaars.
© 2023 Pentair. Alle rechten voorbehouden.

Ave. de Sévelin 20, CH-1004 - LAUSANNE, Switzerland

Alle Pentair-Warenzeichen und -Logos sind Eigentum von Pentair. Eingetragene oder nicht eingetragene Warenzeichen und Logos von Drittherstellern sind Eigentum ihrer jeweiligen Eigentümer.
© 2023 Pentair. Alle Rechte vorbehalten.

Ave. de Sévelin 20, CH-1004 - LAUSANNE, Suíça

Todas las marcas comerciales y logotipos de Pentair indicados son propiedad de Pentair. Las marcas comerciales registradas y no registradas y los logotipos de terceros son propiedad de sus respectivos dueños.
© 2023 Pentair. Todos los derechos reservados.

Ave. de Sévelin 20, CH-1004 - LAUSANNE, Svizzera

Tutti i marchi e i loghi Pentair indicati sono di proprietà di Pentair. Marchi e loghi di terze parti, registrati e non, sono di proprietà dei rispettivi titolari.
© 2023 Pentair. Tutti i diritti riservati.

Av. de Sévelin 20, CH-1004 - LAUSANNE, Suíça

Todas as marcas e logótipos mostrados são propriedade da Pentair. Os logótipos e marcas de terceiros, registados ou não, são propriedade dos seus respectivos proprietários.
© 2023 Pentair, todos os direitos reservados.